

HYBRID-FLO

Black Orchid Hybrid-flo fan with UK plug

The Black Orchid Hybrid-flo combines Axial and Centrifugal technology and is ideal for ventilation systems that require powerful airflows and low noise levels.

Hybrid-flo technology easily handles stronger pressure resistances caused by equipment such as carbon filters.

Hybrid-flo features a 2-speed switch, enabling the user to easily select high or low speed. Hybrid-flo is also compatible with an external speed controller for full and smooth speed control.

The Blaubeurg ball bearing motor gives the fan a service life of over 40,000 hours of continuous operation, whilst the specially designed casing and impeller blades provide higher pressure and a greater air capacity than industry alternatives.



Air flow:
up to 2050 m³/h



Power:
from 23 W



Noise level:
from 27 dBa

DESIGN

- Supplied with 1.8m power cable and fitted UK or EU plug.
- Hybrid-flo impeller technology ensures high airflow levels whilst maintaining low noise levels.
- Protection rating IPX4 and equipped with overheating protection.
- Blaubeurg German Motor.
- Five year Black Orchid warranty.
- Built-in mounting bracket.

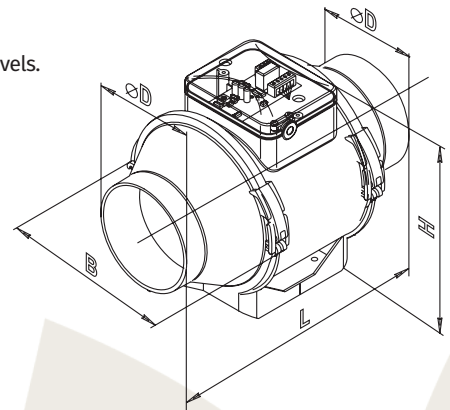

PERFORMANCE

Product	Description	Air Flow [m ³ /h]		Power [w]		Noise Level [dBA]	
		min	max	min	max	min	max
BO-HF-100-UK	Black Orchid Hybrid-flo 4" dia c/w 2-speed switch & UK plug (180/245 m ³ /hour)	180	245	23	25	27	32
BO-HF-125-UK	Black Orchid Hybrid-flo 5" dia c/w 2-speed switch & UK plug (240/350 m ³ /hour)	240	350	25	29	29	34
BO-HF-150-UK	Black Orchid Hybrid-flo 6" dia c/w 2-speed switch & UK plug (415/565 m ³ /hour)	415	565	42	50	37	46
BO-HF-200-UK	Black Orchid Hybrid-flo 8" dia c/w 2-speed switch & UK plug (830/1040 m ³ /hour)	830	1040	76	108	45	52
BO-HF-250-UK	Black Orchid Hybrid-flo 10" dia c/w 2-speed switch & UK plug (1110/1400 m ³ /hour)	1110	1400	125	177	47	55
BO-HF-315-UK	Black Orchid Hybrid-flo 12" dia c/w 2-speed switch & UK plug (1570/2050 m ³ /hour)	1570	2050	230	320	49	58

DIMENSIONS [MM]

Product	ØD	B	H	L	Weight [kg]
BO-HF-100-UK	97	195.8	226	302.5	1.75
BO-HF-125-UK	123	195.6	226	258.5	2.15
BO-HF-150-UK	148	220.1	247	289	2.3
BO-HF-200-UK	199	239	261	295.5	3.95
BO-HF-250-UK	247	287	323	383	7.8
BO-HF-315-UK	310	362	408	445	11.95

PERFORMANCE GRAPHS

BO-HF-100-UK

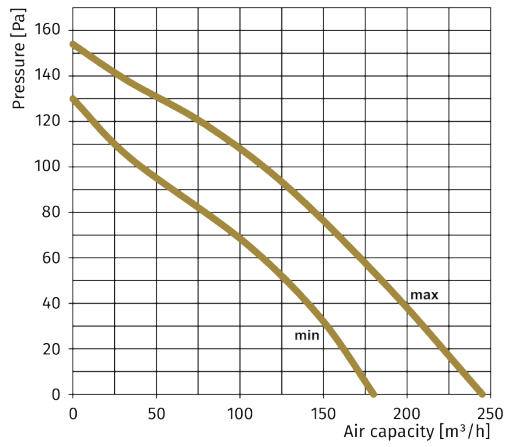

BO-HF-125-UK

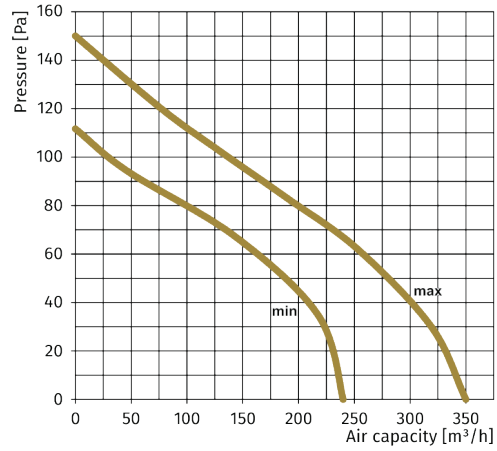

BO-HF-150-UK

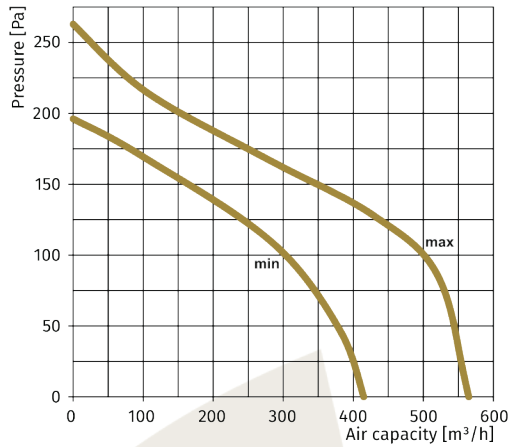

BO-HF-200-UK

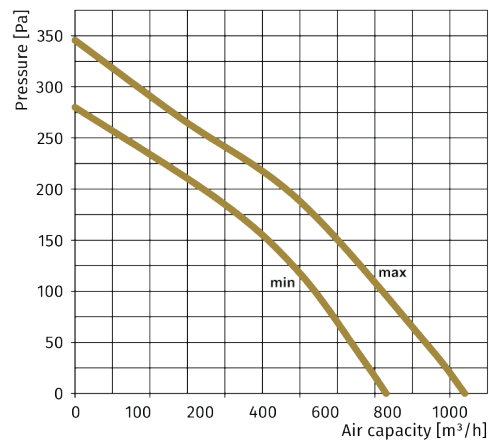

BO-HF-250-UK

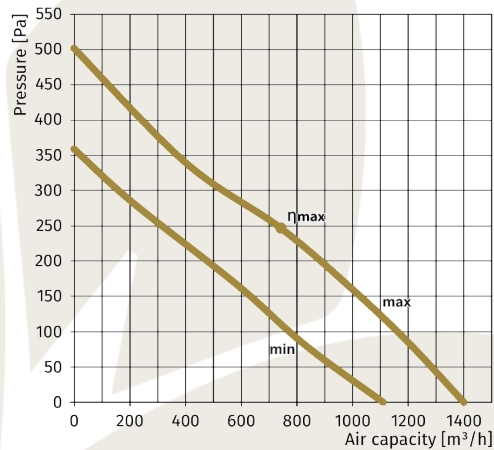

BO-HF-315-UK

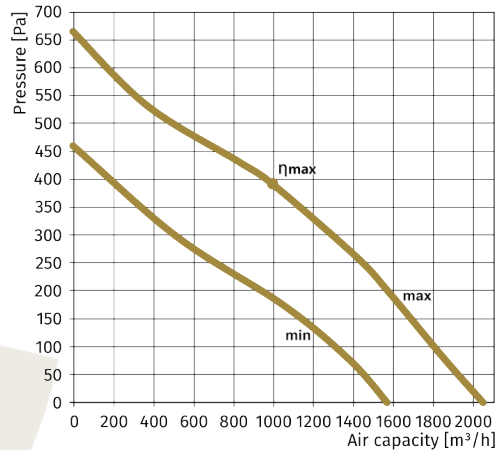

ACCESSORIES

